

Electronic Metering Pumps

Series H9 electronic metering pumps combine the accuracy of microprocessor control with 1000 psi injection pressure capability. These high-pressure, programmable pumps are ideal for applications requiring precise injection of concentrated boiler feed chemicals (Max. Output to 3.2 GPD, Max. Pressure to 1000 psi).

****Minimum System Pressure 200 psi.**

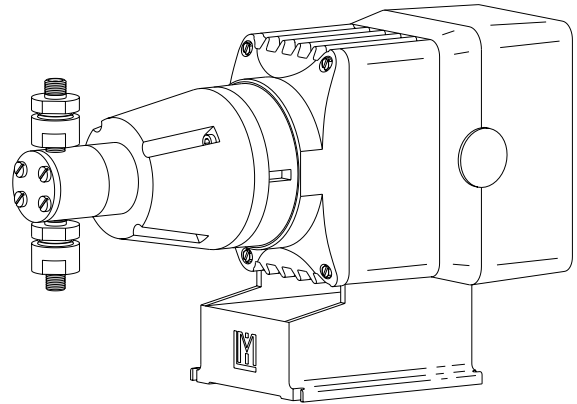

Keypad Adjustable Pressure Capacity

An LMI exclusive, the Series H9 features adjustable pressure control that allows for pressure calibration to your system.

Unique V-Seal Design

LMI's spring-loaded V-Seals prevent leakage and reduce pump maintenance. This design feature eliminates the need for packing nuts normally used on packed plunger pumps.

High-Pressure Module

LMI's precision-engineered, high-pressure module includes a 316 S.S. liquid handling assembly.

The cartridge valves are easily serviced and feature closely-guided 316 S.S. balls and PTFE seats for accurate, repeatable output.

Manual Mode Select

The manual stroke rate is adjustable from 1 stroke per hour to 100 strokes per minute, allowing for extreme output flexibility.

External Mode Select

Three external control modes are available to choose from:

- **Pulse Divide**
(÷) incoming pulses
(reed switch, transistor, opto-coupler, or hall effect sensor)
From 1 to 999
- **Pulse Multiply (Batch Accumulate)**
(x) incoming pulses
(reed switch, transistor, opto-coupler, or hall effect sensor)
From 1 to 999
- **4 - 20 mA (Slope Adjustable)**
Programmable 4 - 20 mA or
0 - 20 mA response direct or inverse

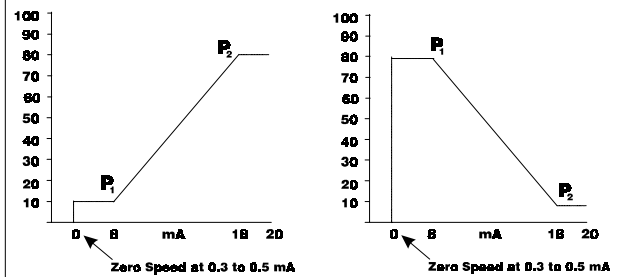

8 Post Office Square
Acton, MA 01720 USA
TEL: (978) 263-9800
FAX: (978) 264-9172
<http://www.lmipumps.com>



Corrosion Resistant Nema 4X (IP65)

Corrosion resistant, O-Ring sealed enclosure of glass-fiber reinforced polypropylene protects the pump from harsh chemicals and tough environments.

The electronic controls and circuitry are fully and permanently encapsulated from protection from moisture and corrosive atmospheres.

Rugged Construction

The Series H9 features a thick-wall, glass-fiber reinforced thermoplastic housing. The integrated plastic and metal structural and magnetic components result in a vibration and shock resistant design not found in competitive products.

Encapsulated ribbon-cable ends provide additional connection strength and corrosion resistance not found in most programmable, electronic-metering pumps.

Dimensions

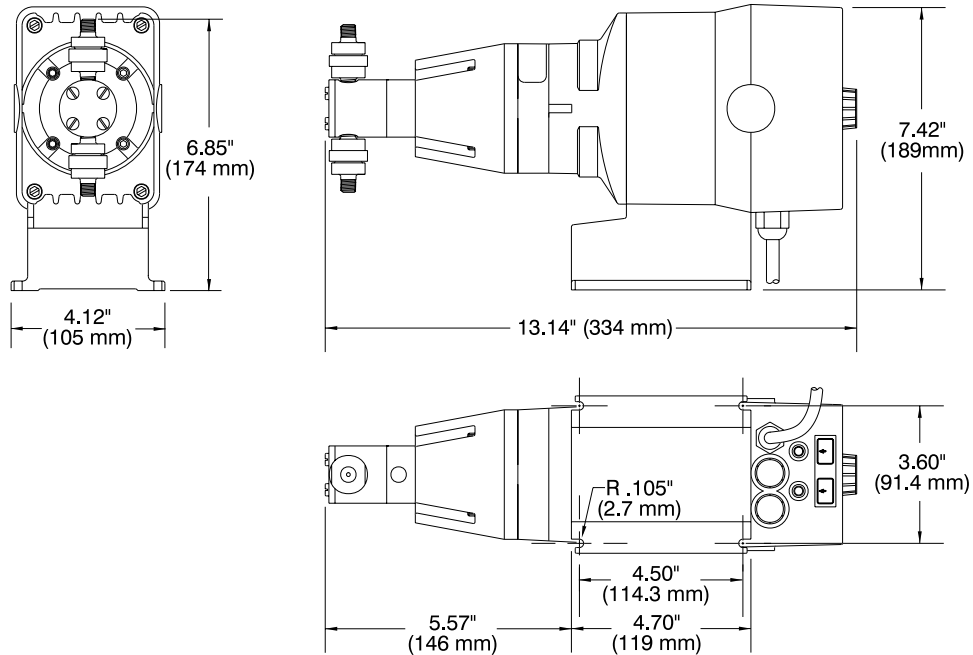

Specifications

Model	Maximum Output Capacity	Maximum Injection Pressure	Volume/Stroke (ml) (Min - Max)	Liquid Handling Assembly	Connections
H91 <input type="checkbox"/> -917	0.14 GPH (0.50 l/h)	300 psi (21 Bar)	.030 – .080	316 S.S.	1/8" NPT M
H92 <input type="checkbox"/> -917	0.10 GPH (0.38 l/h)	600 psi (42 Bar)	.015 – .060	316 S.S.	1/8" NPT M
H93 <input type="checkbox"/> -917	0.07 GPH (0.25 l/h)	1000 psi (70 Bar)	.010 – .040	316 S.S.	1/8" NPT M

When ordering, please indicate desired voltage option by inserting one of the following numbers in the box ().

1 = 120 VAC AC, USA Only
2 = 240 VAC AC, USA Only

3 = 220-240 VAC, DIN Plug
5 = 240-250 VAC, UK Plug

6 = 240-250 VAC, Aust/NZ Plug
7 = 220 VAC, Swiss Plug