

Information Sheet

Back Pressure / Anti-Syphon Valves

LMI's back pressure / anti-syphon valves apply positive discharge pressure to a metering pump system to prevent syphoning and eliminate varying dosage rates caused by fluctuating downstream pressure.

Wetted Materials:

PVC, PP, PVDF and 316 S.S.

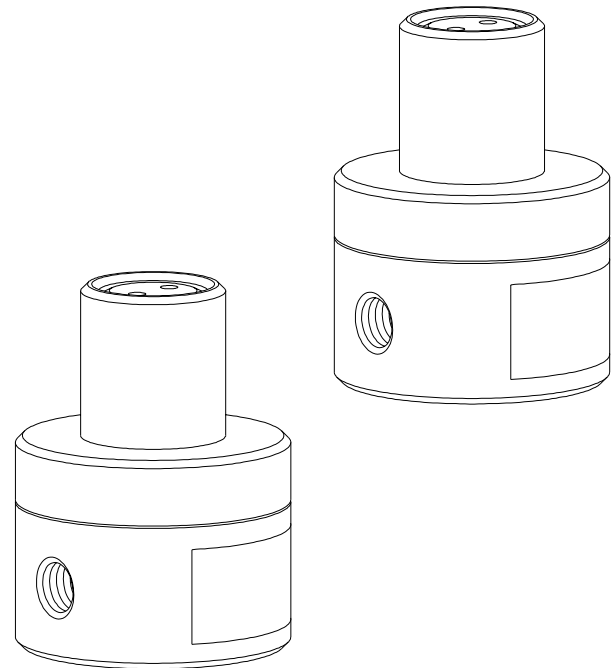

Back Pressure Relief / Anti-Syphon Valve		
Part No.	Size	Material
35637	1/4"	PVC
35638	1/4"	PP
35846	1/4"	PVDF
35847	1/4"	S.S.
35641	1/2"	PVC
35642	1/2"	PP
35850	1/2"	PVDF
35851	1/2"	S.S.
35856	1"	PVC
35857	1"	PP
35858	1"	PVDF
35859	1"	S.S.

Features:

- High Reliability / Low Cost
- Robust, Machined Construction
- Vulcanized PTFE-faced Diaphragm
- Externally Adjustable 0 - 150 psi (10.3 Bar)
- Non-Chatter Design



8 Post Office Square
 Acton, MA 01720 USA
 TEL: (978) 263-9800
 FAX: (978) 264-9172
<http://www.lmipumps.com>



Operation

The diaphragm of the valve is held against the valve seat by an internal spring. When the preset pressure is exceeded, the diaphragm is forced open and solution flows through the valve to the injection point. The valves are preset for 50 psi (3.5 Bar), however, they are field adjustable from 0 to

150 psi (10.3 Bar). Installation should be as close to the injection point as possible to prevent line drainage. It is most important that all other system equipment such as pulsation dampeners and pressure gauges are between the pump and back pressure valve.

Technical Data

Pressure Adjustment: 0 to 150 psi (10.3 Bar) - one spring

Temperature: PVC, PP and PVDF 140° F max (60° C max)
316 S.S. 300° F max (149° C max)

Max. Flow Rates:

Pulsating Flow			Continuous Flow		
1/4 NPT	100 GPH	(378 l/h)	1/4 NPT	300 GPH	(1135 l/h)
1/2 NPT	100 GPH	(378 l/h)	1/2 NPT	300 GPH	(1135 l/h)
1 NPT	500 GPH	(1892 l/h)	1 NPT	1560 GPH	(5904 l/h)