

# Information Sheet

## LiquiPro™ 4-Function Valve

For 300/400 Series Cartridge Valve Type Liquid Ends

### Anti-Syphon

A positive diaphragm-type anti-syphon function makes it possible to meter liquids “down hill”.

### Back Pressure

Supplies approximately 20 psi (1.4 Bar) back pressure to prevent over-pumping when little or no system pressure is present.

### Priming - Pressure Release

This function makes it easy to depressurize the discharge line without loosening tubing or fittings. It also allows you to prime your LMI pump while it is connected to a pressurized line.

### Pressure Relief Function

Provides protection against excessive system pressure

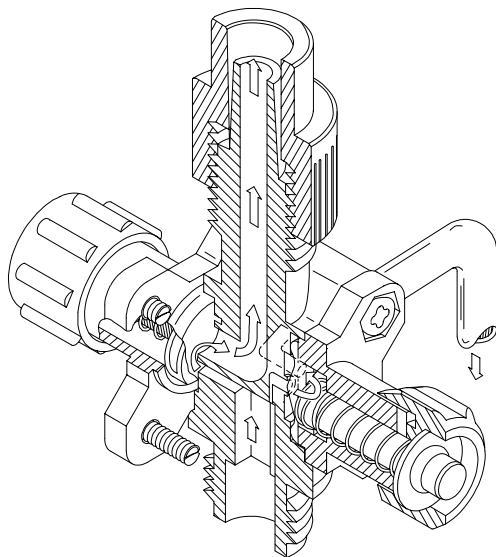
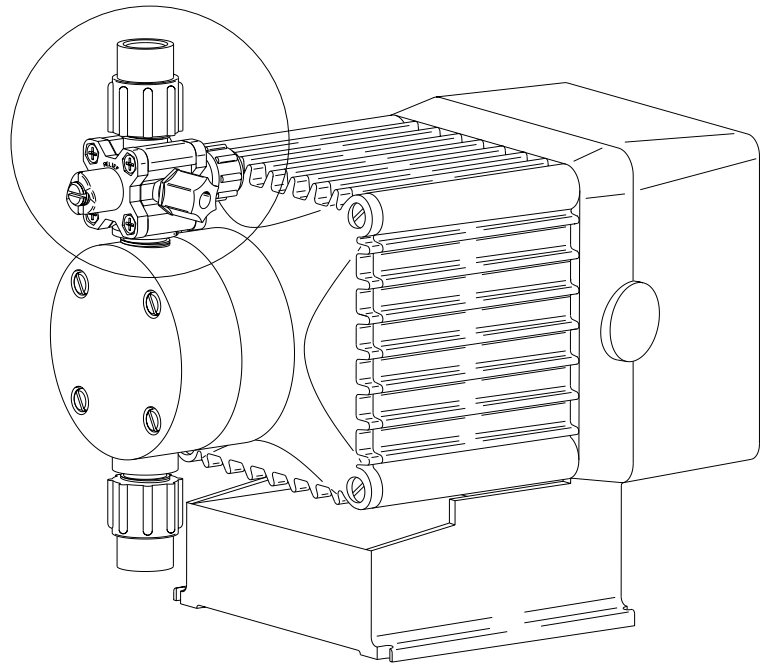

Part No.	Tubing Size	Materials of Construction	
		Diaphragm	Body
36275	1/4" O.D. Tubing	PTFE	PVDF
36276	3/8" O.D. Tubing	PTFE	PVDF
36277	1/2" O.D. Tubing	PTFE	PVDF
36278	1/4" NPT Pipe	PTFE	PVDF
37994	1/4" O.D. Tubing	PTFE	PVC
38003	3/8" O.D. Tubing	PTFE	PVC
38012	1/2" O.D. Tubing	PTFE	PVC
37983	1/4" NPT Pipe	PTFE	PVC

Part numbers are for 300/400 Series LiquiPro™ cartridge valve type Liquid Ends only.



8 Post Office Square  
Acton, MA 01720 USA  
TEL: (978) 263-9800  
FAX: (978) 264-9172  
<http://www.lmipumps.com>



# Instruction Sheet

## LiquiPro™ 4-Function Valve For 300/400 Series Cartridge Valve Type Liquid Ends

### METHOD OF OPERATION

#### A. PRIMING

1. Connect return tubing to (relief) port.
2. Route tubing to solution tank. Be sure the end of tubing is above the maximum solution level (Do not submerge tubing in solution).
3. Turn Relief Knob 1/4 turn to open.
4. Set pump at 80% speed and 100% stroke. Start pump. When solution begins to flow through translucent return tubing, the pump is primed.
5. Stop pump. Turn Relief Knob 1/4 turn to close.

#### NOTE:

- (a) Pump is normally self-priming if suction lift is no more than 5 ft (1.5 m), valves in the pump are wet with water (pump is shipped from factory with water in pump head) and the above steps (A1 through A4) are followed.
- (b) If the pump does not self prime, remove 4-function valve and Discharge Cartridge Valve, and pour water or solution slowly into discharge port until it is filled. Replace Cartridge Valve, and follow steps (A1 through A4) thereafter.

#### B. DEPRESSURIZING DISCHARGE LINE

1. It is possible to depressurize discharge line and pump head without removal of tubing or loosening of fittings.

*Be sure injection check valve is properly installed and is operating. If a gate valve or globe has been installed, downstream of the injection check valve, it should be closed. Be certain return tubing is connected and run to solution supply tank.*

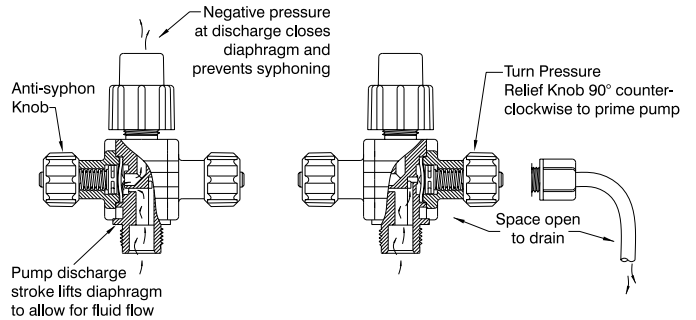

2. Turn Relief Knob 1/4 turn to open.
3. Solution should exit the return tubing. The discharge line is now depressurized.
4. If injection check valve is of higher elevation than pump head, disconnecting tubing at injection check valve end will allow air to enter and cause solution to drain back to tank.

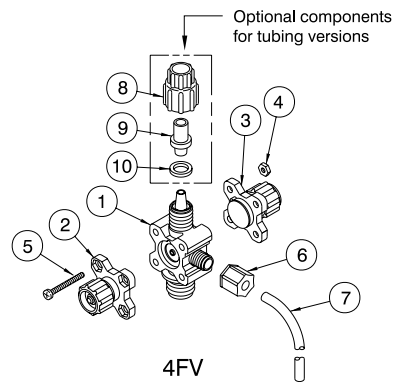

Key No.	Part No.	Description	36275	36276	36277	36278	37994	38003	38012	37983
1	34705	4FV Body, 1/4" PVDF	1							
	34707	4FV Body, 3/8" PVDF		1						
	34709	4FV Body, 1/2" PVDF			1					
	35865	4FV Body, 1/4" NPT PVDF				1				
	38002	4FV Body, 1/4" PVC					1			
	38011	4FV Body, 3/8" PVC						1		
	38016	4FV Body, 1/2" PVC							1	
	37989	4FV Body, 1/4" NPT PVC								1
2	36260	P/R Cap Asm		1	1			1	1	
	36866	P/R Cap Asm	1			1	1			1
3	36280	A/S Cap Asm	1	1	1	1	1	1	1	1
4	25628	Nut	4	4	4	4	4	4	4	4
5	25627	Screw	4	4	4	4	4	4	4	4
6	25631	Coupling Nut	1	1	1	1	1	1	1	1
7	25636-10	Tubing	1	1	1	1	1	1	1	1
	10299	Coupling Nut	1	1			1	1		
8	10411	Coupling Nut			1				1	
	28663	Ferrule	1				1			
10	26136	Clamp Ring		1				1		
	37203	Clamp Ring			1				1	