

Sundyne®

400 hp - Pump Lines
API 610 - OH6



FEATURES

The new LMV-341 has incorporated single throat hydraulics with a more robust 400-hp gearbox. This results in lower minimum flows, thereby extending the operating range of the pump.

The LMV-341 Sundyne gearbox is completely interchangeable with the old LMV-331 gearbox. Some minor external adjustments may be required.

Key Features

- Large 1 3/4" (44.5mm) high speed journal bearings.
- High speed shaft with integral gear and balanced idler shaft with sleeved bearings to insure a low vibration unit and extended seal life.
- Lube oil reservoir located in both the idler shaft and the high speed shaft eliminates the need for the lube oil priming pump for vertical configurations.
- Roller bearings on the input shaft with a minimum of 100,000 hours L₁₀ bearing life.
- Upgraded oil filter with a rating of 3 micrometers @ 200 Beta ratio, ISO extended code 14/12/10, resulting in extended bearing, seals and greater life.
- Internal lube oil pump with reversing capability providing bearing lubrication even if the pump motor is turning backwards.
- 16 pitch spur gears manufactured to AGMA class 11 thereby increasing the AGMA rating.
- All gearbox split lines are sealed with o-rings eliminating an oil leak path.
- A new innovative lip-labyrinth seal on the input shaft eliminating shaft wear and gearbox contamination.
- Integral lube oil filter manifold eliminating an oil leak path.

PERFORMANCE

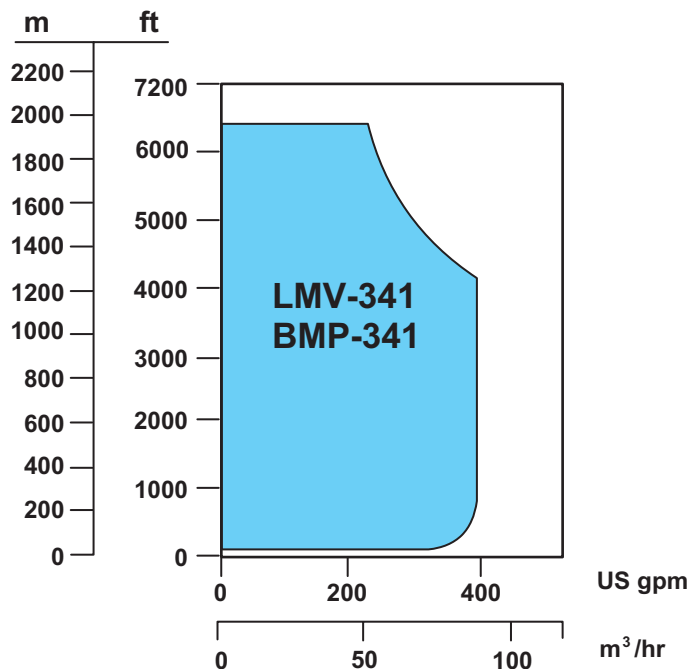

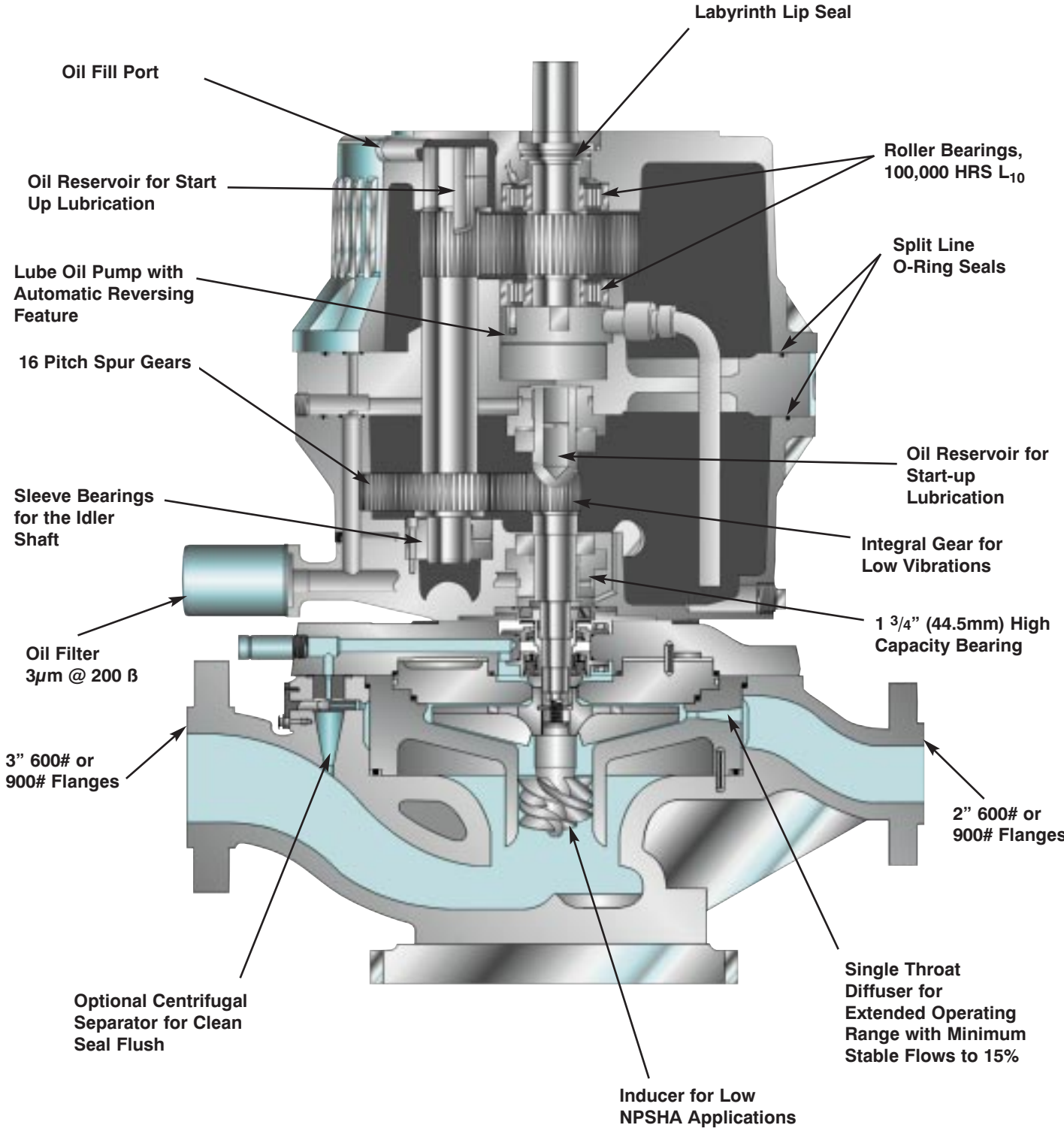

OUTLINE DRAWINGS

LMV-341
with Vertical Stand
(Optional)

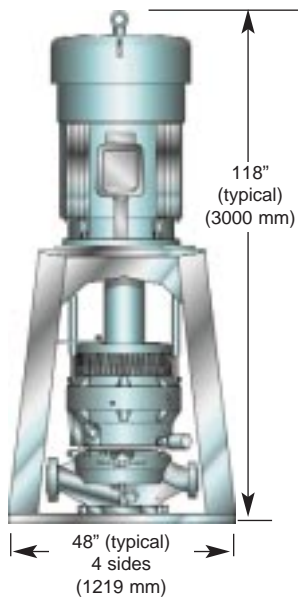

LMV-341
(Standard Only)

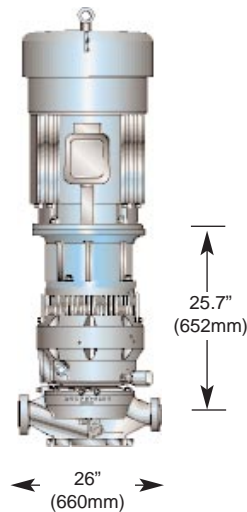

BMP-341

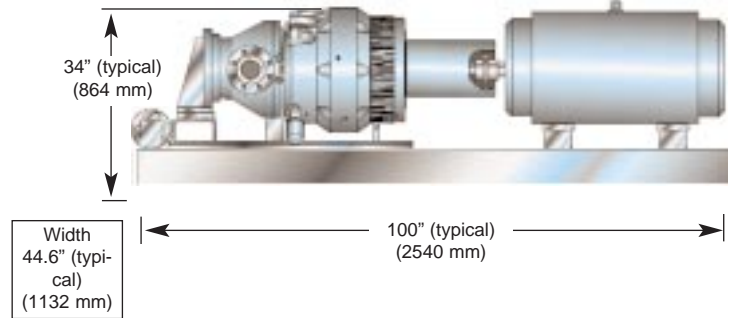

Manufacturers Representatives, Service Centers and Direct Offices throughout the World

For a complete list please visit our website at www.sfh.com



Sundstrand Fluid Handling (Arvada, Colorado) and Sundstrand International, S.A. (Dijon, France) are pleased to provide our customers with the added quality assurance benefits of an ISO9001-1994 Quality Management System. Our Quality Management System is certified by Lloyd's Register Quality Assurance, Limited. The certification includes all Sundyne, Sunflo, Sundyne Canned Motor Pumps, Kontro and Sine products designed and manufactured at both plant locations.

MANUFACTURING LOCATIONS

SUNDSTRAND 
FLUID HANDLING

Arvada, Colorado USA
Phone: +1-303-425-0800
FAX: +1-303-425-0896

SUNDSTRAND 
INTERNATIONAL S.A.

European Sales
Phone: +32-2-721-5045
FAX: +32-2-725-9820



Member of
Hydraulic
INSTITUTE

© Sundstrand Fluid Handling Corporation 1998
All rights reserved

• ANSIMAG • HMD • KONTRO • MASO • SINE • SCMP • SUNDSTRAND COMPRESSORS • SUNDYNE • SUNFLO •